

# E-TON

Powered by Heart

## MATRIX R4-150

### OWNER'S MANUAL



Copyright ©2008-2009 ETON America, all rights reserved.

E-TON E-TON E-TON E-TON E-TON

Dear Customer,

Thank you for choosing the ETON Beamer.

This scooter was made in accordance with the international QS9000 standards and the directives of the European parliament and council. It conforms to all Federal DOT regulations for a class Amoped.

It was engineered and designed to provide a reliable form of economic transportation for your life style. This manual was designed to provide you with the basic understanding of the structure, function, operation and maintenance of the Beamer Scooter. By following the instructions in this manual, you will be able to maintain the performance and prolong the service life of your Beamer Scooter.

We at ETON wish you many years of pleasurable driving.

ETON America, LLC.

## **Important Notices**

### **READ and UNDERSTAND** this owner's manual

The operator should completely read and understand this owner's manual before operating this vehicle. This owner's manual will instruct you in the safe operation of the vehicle. This manual contains warnings and cautions for some specific service methods which could cause personal injury and/or damage to the vehicle.

### **ALWAYS Wear Protective Clothing**

While operating this vehicle, the driver must always wear protective clothing. Protective helmet with face shield, and hard soled boots should always be worn when operating this vehicle.

### **OBEY all State and local laws and regulations**

Each state and local governing agency has laws and regulations for scooter operations. It is the owner's responsibility to know, understand and obey these laws and regulations.

### **SPEED RESTRICTION Devices**

This vehicle is equipped with electronic speed limiting devices. Any attempt to change, over-ride or bypass these devices may cause dangerous operating conditions.

Due to continuing upgrades to our product line, information in this manual is subject to change without notice. Please contact your local dealer for further information regarding current information about your Beamer scooter.

## Table of Contents

Vehicle Identification Number Location	3
Controls, Switches, and Feature Locations	3
Control Feature Operations	
Engine Stop Switch	4
Turn Signal Switch	4
Horn Button	4
Manual Choke Lever	4
Headlight Control Switch	4
Ignition Control Switch	5
Instrument Panel	5
Throttle Control	5
Throttle Cable Adjustment	6
Brake Systems	
Front & Rear Brakes	6
Brake System Inspection	6
Hydraulic Fluid Reservoir	7
Purging the Brake Lines	8
Fuel System	
Fuel Tank	8
Fuel Cap	8
Inline Fuel Filter	9
Engine Oil	
Oil Indicator Light	9
Checking the Engine Oil Level	9
Changing the Engine Oil	10
Changing Transmission Oil	10
Cleaning Air Filter	11
Tire Pressure	11
Spark Plug	11
Air Filter	11
Electrical Battery	12
Front Forks	12
Engine Oil Cooler	12
Break-In Procedure	13
Pre-Operation Inspection Procedure	13
Starting Procedure	13
Driving Your Scooter	14
Parking Your Scooter	14
Specifications	15
Maintenance Schedule	16
Wiring Diagram	17
Reporting Safety Defects	18
Manufacturer's Warranty	19

# Vehicle Identification Numbers

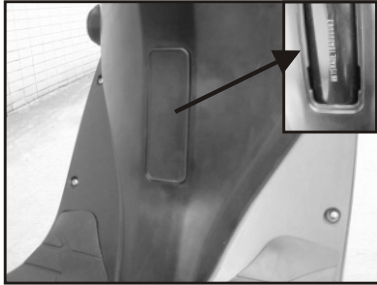

Your VIN \_\_\_\_\_

Vehicle Identification Number (VIN) is located on the frame behind the foot guard and is covered by a small plastic cover plate which can be removed with a screwdriver.



Eng. Number \_\_\_\_\_

Engine serial number is located on the left-hand side of the engine on the crankcase housing.

# Controls, Switches & Feature Locations

## Locations of controls and features

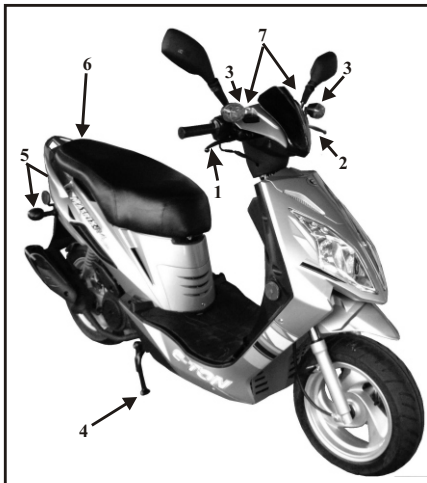

1. Front Brake lever
2. Rear Brake Lever
3. Front Turn Indicator Lamps
4. Main Parking Stand
5. Rear Turn Indicator Lamps
6. Fuel tank Cap
7. Brake Fluid Reservoir

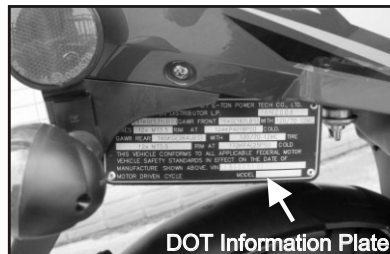

DOT Information Plate

# Control feature operations

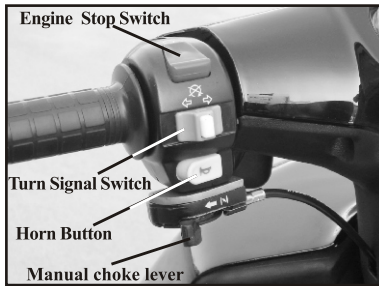

## Left Handlebar Controls

### Engine Stop Switch

The stop switch is a red colored rocker switch located on the left-hand handlebar.

To start and run the engine, this switch must be placed in the on, "↻" position.

The vehicle is also equipped with a safety brake switch which will prevent the engine from starting until the parking brake is engaged.

To stop your engine, place the switch to the stop, "⊗" position

In the stop, "⊗" position the ignition system is grounded preventing the spark plug from firing.

This switch can also be used as a safety or emergency stop switch.

### Turn Signal Switch

The turning signal switch is a three position switch located on the left-hand handlebar. Sliding the switch in the direction of the intended turn will illuminate the front and rear turn signal lamps in a blinking mode. Pressing the white button, on the center of the switch, will return the switch to the neutral position and cancel the illumination of the turning lamps.

### Horn Button

The horn button is a yellow push switch, located below the turning signal lamp switch on the left-hand handlebar. Pressing in on the button will sound the audible horn signal. Releasing the button will silence the horn.

### Manual choke lever

This choke is operated by the lever at the bottom of the left hand control switch.

When first starting the engine,(cold start), place the lever in the full left position, (Choke closed or on) As the engine warms return the lever to the full right position. (Choke open or off).

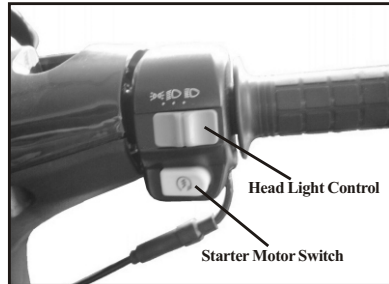

## Right Handlebar Control

### Head Light Control Switch

For safety, the head light system of this unit was designed to be illuminated at all times while the unit is running. The intensity of the light is changed by using the head light control switch located on the right-hand handlebar. It is a three position slide switch. Far right position sets beam intensity to 20% (Day Time Running), middle position sets beam intensity to 80% (Low Beam), and far left position sets beam intensity to 100% (High Beam).

The vehicle is equipped with a PTC controller that will dim the lights to the 20% position automatically if the engine RPM falls below the pre-set threshold for more than a minute. Increasing the engine RPM will return the light to the normal level for the control switch selection.

## Ignition Switch

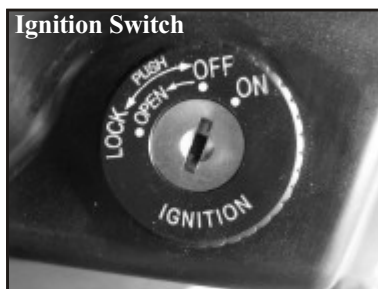

The ignition switch is located on the control column's right side below the handlebars. A key is required to work the switch. This switch has three positions, "ON", "OFF", "OPEN" and "LOCK". The switch must be in the "ON" position for the engine to start and run. The "OFF" position disconnects power to the ignition and light circuits and stops the engine. The "OPEN" position can open the seat when you want to use the storage compartment under the seat. The "LOCK" Position locks the steering column and allows the key to be removed. In order to turn the key to the "LOCK" Position you must press down on the key with the steering column turned slightly to the left.

**NOTE:** Always lock your vehicle when leaving it unattended and take your keys for additional security against theft of your vehicle.

## Instrument Cluster



The instrument cluster provides you with operating conditions of your vehicle. To the left is the fuel gauge which indicates the fuel

level in the fuel tank. When the needle reaches the red zone on the gauge, you are running low on fuel and the tank should be refilled. This gauge is controlled by a fuel level sending unit located inside the fuel tank.

The center speedometer indicates the current speed of your vehicle. The speedometer is calibrated in both MPH, (Miles per hour) and KPH, (Kilometers per hour). This gauge is controlled by a cable attached to the front wheel of the vehicle.

The right side is a series of three indicator lamps. The top most lamps in the cluster will indicate that the turn signals have been activated and also indicates which signal lamps are illuminated.

The right indicator lamp indicates the head light controller is in the Hi-Beam, 100%, position when illuminated.

The left lamp indicates the 2 cycle oil level in the oil tank. When illuminated your oil tank is low and needs to be refilled. Continued operation of the engine with a low oil condition will cause sever damage to the engine and potentially unsafe operating condition. Refill your oil tank with High grade JASO FC 2 cycle injector oil.

## Throttle Control

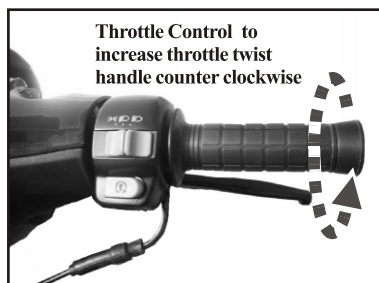

The throttle control is the right-hand handle grip. Throttle is controlled by twisting the grip. The throttle control is spring loaded and set at the factory to return to the idle position when pressure is released.

To increase the throttle, twist the handle grip in a counter clockwise rotation. To decrease throttle, twist the hand grip in a clockwise rotation or release your pressure and allow the throttle to return on it own.

The throttle cable should be adjusted so there is 5-10mm, ( $\frac{1}{4}$ " ) free travel of the throttle hand grip before the throttle starts to open.

Keep the throttle cable lubricated and operating smoothly. If the cable sticks or is hard to operate, lubricate the cable by disconnecting the cable from the throttle hand grip and lubricating with a commercial cable lubricant available at your dealer.

Replace the cable if it shows signs of fraying or corrosion or is kinked or bent.

## Throttle Cable Adjustment

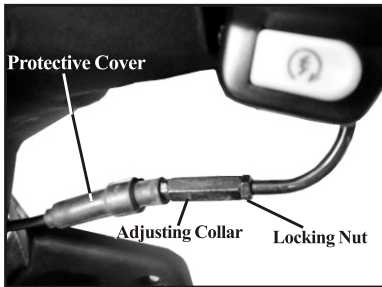

To adjust the throttle cable's free play, slide the protective cover down the cable to expose the cable adjusting system. Loosen the locking nut and adjust the cable length by turning the adjusting collar. Check the free travel in the throttle hand grip until you have 5-10mm, ( $\frac{1}{4}$ " ) free travel. Tighten the locking nut against the adjusting collar and slide the protective cover over the adjusting system. Replace the cable if there is no adjustment remaining or the proper free travel can not be obtained with the adjustment system.

## Brake Systems

### Front and Rear Brakes

The vehicle is equipped with front hydraulic disc brake and a rear hydraulic disc brake.

The front brake is controlled by the long brake lever on the right-handlebar.

The rear brake is controlled by the long lever on the left-Handlebar.

The rear brake is the primary stopping brake on your vehicle. Using the rear brake to stop your vehicle will prevent steering control loss.

Use your front and rear brakes in combination to control your speed while descending a grade. Use caution not to apply too much pressure to your front brake so that the wheels lock up, stop turning, and cause a loss of steering control. If the front wheels lock up, stop turning, lightly reduce the pressure on the front brake lever until it unlocks and the wheel start to turn.

## The Brake System Inspection

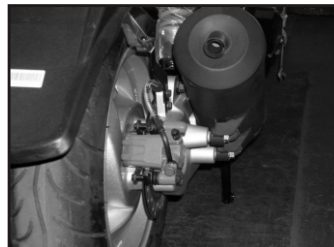

Visually inspect the brake lines for any signs of wear. Inspect the lines for leaks at all connections and look for wear along the entire line. Replace the line if any worn areas are found. The brake line is under great pressure when the brakes are applied and any worn spot could cause a rupture of the line.

Inspect the brake arm, spring, rod and fastener for signs of wear or damage. Operate the brake lever while watching the brake mechanism for proper operation. Tighten, repair or replace parts as needed to insure safe brake operation. Clean any build-up of mud or debris from the brake mechanism.

The brakes are equipped with a wear indicator to alert you when your brake pads need replacing. Apply light pressure to the brake lever and slowly push the unit forward. If you hear a high pitched metallic scraping sound, you need to replace your brake pads. The minimum pad thickness is 3.0mm.

**DO NOT RIDE A VEHICLE WITH WORN BRAKE PADS.**

Check the rotor disc for cracks, warping or color distortion. Replace rotor disc at first sign of problem.

Check rotor disc thickness. Minimum thickness is 3.1mm. Replace the disc if below minimum thickness.

Check the fluid level in the fluid reservoir by checking the site glass for the level.

The fluid level should fill at least  $\frac{3}{4}$  of site glass when the unit is setting on a level surface.

Test the brakes by applying pressure to the brake lever and trying to push the unit forward. If the wheel rotates while the brakes are applied, check your fluid level and brake pads. If the brake lever feels spongy or does not stop when squeezed, you may have air in the lines. All air must be purged from the brake lines for the disc brake to operate properly. (See purging brake lines).

## Hydraulic Fluid Reservoir

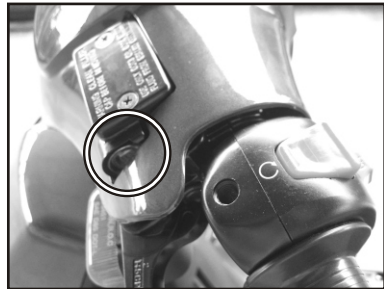

Remove the reservoir cover by removing the two cover bolts.

Fill the reservoir to  $\frac{1}{8}$ " from top with Dot-3 SAE-J1703 grade brake fluid.

**Caution: DO NOT** allow dirt to fall into the reservoir.

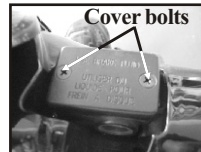

Refold the cover gasket as shown in picture and replace cover and bolts.





## Purging The Brake Lines

For the hydraulic brake system to operate safely, the brake system must be purged of air in the lines and reservoir.

To bleed the air will require two people to perform the following procedure.

1. Place a drain pan under the brake caliper to catch the fluid.
2. Open the bleeder valve  $\frac{1}{2}$  turn counter clockwise.
3. Squeeze the brake lever to expel air from the system.
4. While holding the brake lever, close the bleeder valve.
5. Repeat steps 2 through 4 until the brake fluid coming from the bleeder valve is a solid stream without any air, then close the valve and replace rubber protection cap.
6. Test the brake system by squeezing the lever. The lever should feel firm and stop without fading.

## Fuel System

### Fuel Tank



The fuel tank fill cap is located at the rear of the vehicle just behind the seat. Your vehicle is equipped with a locking fuel tank cap that is opened with the same key that is used in the ignition switch.

To unlock your cap simply insert the ignition key into the lock and turn clockwise until the cap releases. Lift the cap from the tank and refuel your vehicle with unleaded automotive grade gasoline of 89 octane or higher.

### Fuel Cap

To replace the cap, align the locator lug on the cap with the notch in the tank neck and press the cap down until you hear the locking lugs click.

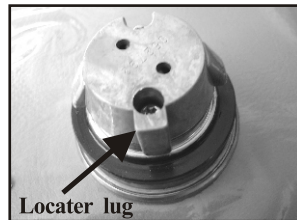

Every time you refuel your unit, check the rubber seal inside the cap for cuts, tears and dirt. Clean or replace the seal if it becomes worn or torn. The seal must be in good condition to insure a proper seal of the cap to the tank to prevent fuel spills. DO NOT allow dirt or other debris to enter the tank when refueling.



Replace the cap if damaged or if it will not seal to the tank.

The fuel tank capacity is 5.5 liters, 1.5 gal.

**NEVER REFUEL YOUR VEHICLE when the engine is running or with a hot exhaust system.** Wait 30 minutes after turning off the unit before refueling. Spilling fuel on a HOT engine or exhaust could cause a fire. Wipeup anyfuelspills before restarting.

## Inline Fuel Filter

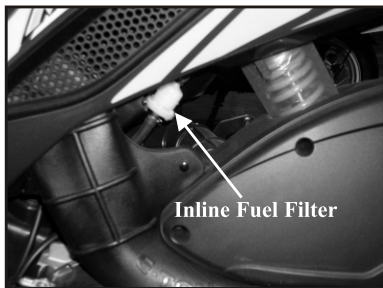

Your vehicle is equipped with an inline fuel filter to prevent dirt and debris from entering the carburetor and engine.

The filter should be replaced every 10,000 miles or each year of operation.

Replacement and fuel line inspection should be preformed by an authorized ETON dealer only.

**DO NOT** start or operate the engine if the fuel filter or lines are leaking. Leaking fuel can cause a fire.

## Engine Oil

Your vehicle uses 2 cycle oil to lubricate the engine. The oil tank is located under the seat at the front of the unit. Oil is drawn from this tank by an oil injector pump when the engine is operating.

## Oil Indicator Light



The unit is also equipped with an oil level indicator lamp. The lamp will light when the oil level in the tank is low. When the lamp is lit you **MUST** refill the oil tank.

**DO NOT** allow the engine to operate with an empty oil tank. Doing so will result in extensive damage to your engine. This damage is not covered under the warranty.

## Checking Engine Oil Level

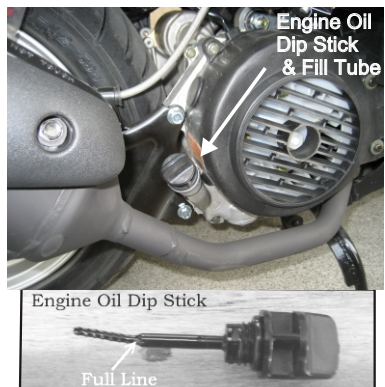

Your Scooter uses automotive type engine oil to lubricate the engine. The engine oil dip stick is located on the right hand side of your engine below the transmission shifting lever.

To check your oil level, remove the dip stick by turning the thumb hold counter clockwise until the stick has been completely disengaged from the threads. Pull the dip stick out of the crankcase and check the level of the oil as indicated on the dip stick. The engine oil is full when the oil reaches the level on the stick as indicated in the photo above.

Always check your engine oil level with the engine off and cold. Removing the dip stick with the engine running could cause hot oil to splash from the crankcase causing severe burns.

Checking your engine oil while the engine is hot can give you a false reading; always check the oil level with a cold engine.

Your engine requires SAE 15w/40 engine oil and the crankcase capacity is 1.0 Liters / 1 quart.

The engine oil should be changed before the start of each riding season or every 300 hours of operation. When riding where conditions are

dusty or humidity is high the engine oil should be change more frequently.

## Changing Engine Oil



1. Place an oil catch pan under the unit directly below the engine crankcase.
2. Remove the crankcase drain plug located on the bottom of the crankcase on the underside of the unit.
3. Remove the engine oil dipstick located on the right hand side of the engine below the shifter shaft.
4. Allow the oil to drain completely (15-30 min).
5. Reinstall the drain plug and tighten.  
Torque to 7-101bf-ft

6. Fill the crankcase with of SAE 30W engine oil through the dip dipstick hole. 1 liter/1 quart.
7. Reinstall the engine oil dipstick and finger tighten.
8. Dispose of used oil at a proper recycling station as required by law

## Changing Transmission Oil

Your Scooter uses SAE 80/90W gearoil to lubricate the drive and transmission gears.

The gear oil should be changed before each riding season or every 1000 hours operation.



1. Place an oil catch pan under the unit directly below the transmission box.
2. Remove the transmission box drain bolt.
3. Remove the transmission box fill hole bolt.
4. Allow the oil to drain completely (15-30 min).
5. Reinstall the drain bolt.and tighten.  
Torque to 7-101bf-ft
6. Fill the transmission box with of SAE 80-90 gear oil 150cc Engine = 180cc /6.1oz
7. Reinstall the fill hole plug and torque to 2-31bf-ft.
8. Dispose of used oil at a proper recycling station as required by law

# Air Filter



## Air Filter Maintenance

To maintain the highest performance from your engine and to reduce excessive wear that could cause engine failure the engine requires a continuous flow of clean air. Air is taken into the engine through an air filter to clean the air prior to mixing it with fuel and oil in the carburetor.

During normal operation the filter accumulates dirt from the air and will need to be cleaned to maintain the proper air flow. The filter should be cleaned every 3000 miles, more often if you ride in a dusty or dirty environment and the element should be replaced every year.

The air filter box is located on the left side of the engine under the body cover. It is a black box about 6" square and is attached to the crankcase with two bolts and the carburetor by a tube.

## To clean the filter

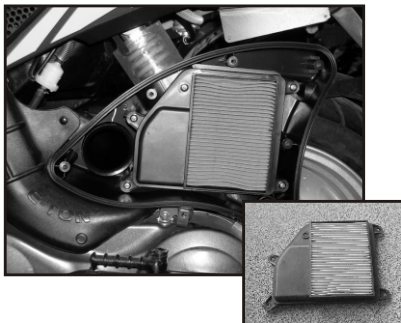

Remove the air filter box cover.  
Remove the filter element from the air box.

Wash the element in a non-flammable solvent such as Air-Filter cleaner from your local auto parts dealer.

1. Dry the element completely before continuing.
2. Soak the element in clean engine oil until completely saturated.
3. Squeeze out the excess oil until the element does not drip any oil.
4. Allow the element to dry then reinstall the element and cover.

# Tires and Wheels

The tires and wheels of your Beamer have been engineered to match the suspension to give you a smooth, comfortable ride. They were also designed to afford you with mileage economy, to give you the best miles per gallon possible.

## Tire Pressure

Recommended tire pressure (Cold) is:

Front 18psi / 1.25kg/cm<sup>2</sup>  
Rear 25psi / 1.75kg/cm<sup>2</sup>

# Spark Plug

Replace the spark plug every 10,000 miles or if the plug should become damaged or fouled. We recommend that you use NGK - BPR7HS.

Disconnect spark plug wire.

Clean dirt from around spark plug base with brush or air. (Caution: do not allow dirt or foreign material to enter the engine)

Remove spark plug with spark plug wrench. Set the spark plug gap on the new plug to 0.023". Install the new plug screwing it in finger tight and then use the plug wrench to screw the plug in another 1/2 turn.

Inspect the spark plug wire for cuts, nicks or other damage. Replace as needed.

# Electrical Battery



The unit's battery is located under the floor board mat and supplies electrical power to the unit. The battery is a 12 volt gel acid type that contains no liquid electrolyte. The battery should be removed from the vehicle when stored for extended periods and charged before being replaced in the unit. Use a trickle charger set at 12 volts to recharge the battery to full charge before replacing it in the unit.

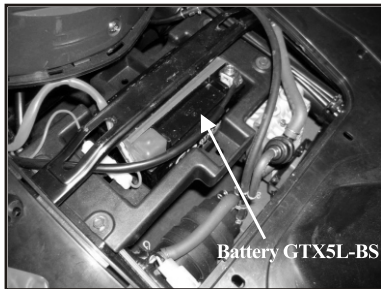

When reinstalling the battery, be sure to connect the red cable to the positive (+) terminal and the black cable to the negative (-) terminal.

The battery should be replaced every three years or when it no longer holds a charge.

Do not expose the battery, for extended periods of time, to freezing temperatures. If the battery has been frozen it will need to be replaced.

There is an inline fuse on the positive lead of the battery to protect the wiring system from over loads. If your starter motor will not turn

over and the battery is fully charged, check the inline fuse on the unit.

Replace the fuse with a 7A fuse.

# Front Forks

Check the front forks of your vehicle for signs of damage or leaking oil. If either is noticed, return the vehicle to your dealer for service.

# Engine Oil Cooler

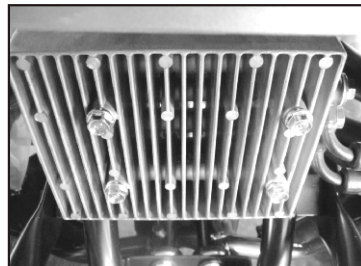

The engine oil is cooled by pumping the oil through an external oil cooling radiator located at the front of the unit. It is important that the cooling fins of the radiator be kept clean of dirt build up to prevent engine overheating. Remove any build up of mud and dirt from the cooling unit with a pressurized spray of water.

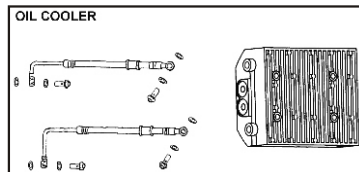

Inspect the Oil cooler line for leaks and damage. Replace any damaged lines and repair any leaking connections before starting the engine.

## **Beamer Break-In procedure**

Your Beamer requires a break-in period just as with all other internal combustion engines. This period allows the engine parts to seat and wear properly without undue strain which can cause premature failure.

1. For the first 1000 miles of operation do not operate your vehicle above 18mph. for extended periods of time.
2. Your first tank of fuel should be a pre-mixture of fuel and oil at a 50:1 ratio. This will insure that the oil pump system has been primed and bled of air that may have occurred in shipping.
3. Do not over rev the engine.
4. Use light braking pressure to allow the brake pads to seat to the rotor and drums.

## **Pre-Operation Inspection procedure**

**The following procedure must be performed before each operating session.**

Checking your Scooter takes only a few minutes and may save you from serious injuries and costly repairs.

1. Check engine oil level.
2. Check engine fuel level.
3. Check brake operations and brake fluid level.
4. Check tire condition and pressure.
5. Check throttle operation and free play adjustment.
6. Check engine stop switch for proper operation.
7. Check steering system. Look for free and smooth operation. Check all fastening hardware.
8. Check all nuts, bolts and other fasteners for loose conditions.
9. Inspect unit for any broken or damaged parts.
10. Check all indicator lights and switches for proper operation.
11. Insure you are wearing proper clothing and protective gear, such as helmet and hard soled shoes.

## **Starting Procedure**

**The following procedure must be followed each time you start your Beamer.**

Park the unit on a level surface. Insert the key into the ignition switch and turn to the "ON" position.

Turn the engine stop switch to the "⌚" position.

Apply slight pressure to the throttle grip. Hold in both brake levers while pressing the starter button on the right handlebar switch.

NOTE: Your Beamer is equipped with a safety brake interlock switch which will prevent the engine from starting without the brakes being applied.

Your unit should start within 10 seconds of pushing the starter button. If the unit fails to start check the following:

1. Engine stop switch is "⌚".
2. Brake levers applied

If your battery does not have enough charge to turn the starter motor you can use the alternate kick starter to crank the engine.

Swing the kick starter foot peddle to the out board position and while holding both brake levers, apply a quick downward push to turn the engine over.

## Driving your scooter

Your Beamer was manufactured to meet all Federal D.O.T. regulations. State and local regulations govern the use of this class of vehicle. Check with your local DMV office before riding this vehicle on the highway.

Set yourself in a comfortable position on the seat with both hands on the handlebars. Ensure that you have an unobstructed operating area from which to control your Beamer. When carrying a passenger, always insure that they place their feet on the

passenger pedals. Always keep your feet on the footrests and your hands on the handlebar grips while operating your Beamer. Doing so will give you the best control of the unit.

Be sure that you and your passenger are NOT wearing loose fitting clothing that could become entangled in the moving parts of the vehicle.

Start the vehicle in a forward motion by slowly increasing the throttle pressure.

Never place more than 12lbs / 5kg load on the rear rack. Doing so may cause the vehicle to become unbalanced and cause an unsafe driving condition.

Never carry anything on the handlebars or your lap while driving your vehicle. Doing so can cause a loss of control over the vehicle.

Learn to steer your scooter by shifting your weight in the direction of the turn. (Lean into the turn)

Use your front & rear brakes to control your speed and to stop. Sudden braking force can cause the vehicle to start sliding. To regain control, release the braking pressure until you have regained control of the vehicle.

When the road surface is wet, the braking distance is double that of when the road surface is dry.

Keep a safe distance between yourself and the vehicle in front of you.

It is not recommended to operate this vehicle

in slippery conditions such as on snow or ice covered roads.

When going downhill, release the throttle grip and use your brakes to control your speed.

After washing your vehicle your brake shoe and pad may have become wet and will reduce the braking force until they have had a chance to dry.

## Parking your scooter

1. Always park your vehicle on a level surface.
2. Turn the ignition key to the "OFF" position to stop the engine.
3. Set the engine stop switch to "OFF" position.
4. Turn your front wheel slightly to the left and turn the ignition key to the lock position to lock the steering column.
5. Remove the ignition key to prevent unauthorized use or theft of your vehicle.
6. Park the vehicle by using either the main parking stand or the side kick stand. The stands are located on the left-hand side of the vehicle.



# Specifications

<b>Engine</b>		
Type	Forced Air/Oil-cooled, 4-stroke	
Displacement	149.5cc	
Bore / Stroke	φ 57.4 * 57.8mm	
Compression	9.7 : 1	
Power	11ps @ 7500rpm	
<b>Transmission</b>		
Type	Automatic(C.V.T.V-Belt)	
<b>Chassis</b>		
Overall Length	1830mm / 72.0"	
Overall Width	650mm / 25.6"	
Overall High	1180mm / 44.0"	
Wheel Base	1260mm / 49.6"	
Dry Weight	103kg / 227lb	
<b>Suspension</b>		
Front	Telescopic Fork	
Rear	Unit Swing Arm / Dual Shock	
<b>Brakes</b>		
Front	Hydraulic Disc	
Rear	Hydraulic Disc	
<b>Tires</b>		
Front	120/70-12	
Rear	130/70-12	
Tire Pressure	Front 18psi / 1.25kg/cm <sup>2</sup> (Cold) Rear 25psi / 1.75kg/cm <sup>2</sup> (Cold)	
<b>Carburetor</b>		
Make/Size	Kei-Hin with Manualchoke	
Main Jet	#108	
Pilot Jet	#35	
Air Mixture Adjustment	Back out 1 - 2 turns Idle 1600 - 1800rpm	
<b>Battery</b>		
12V-9AH-GTX9		
<b>Fluids</b>		
Fuel	Type	Unleaded Gasoline 89 octane
	Volume	6.5liters / 1.7gal
Engine Oil	Type	SAE 15w/40
	Volume	1.0 liters / 1gt
Transmission	Type	SAE 80/90 weightgear Oil
	Volume	180cc / 6.1oz
<b>Spark Plug</b>		
NGK (recommended)		CR7HSA/NGK
Nipendenso		U22FSR-U
Champion		RZ96C(Not recommended)
	Electrode Gap	0.6-0.7mm / 0.023"-0.027"
Max Driver/Passenger Weight		150kg / 330lbs.
Subject to change without notice		

※ Information is subject to change without notice.

Copyright ©2008-2009 ETON America, all rights reserved.



# Maintenance Schedule

	First week	Every 30 Days	Every Year	Notes
Fuel Lines			I	Replace Fuel & Vent Lines every 2 years
Throttle Operation	I	I		Inspect as part of pre-ride inspection
Air Filter		C	R	
Fuel Filter			R	
Spark Plug		I	R	
Drive Chain	I, L	I, L		
Brake Shoes		I	I	
Brake System	I	I		Inspect as part of pre-ride inspection
Brake Fluid	I			Inspect as part of pre-ride inspection Replace every 2 years
Bolts, Nuts & Fasteners	I	I		Inspect as part of pre-ride inspection
Wheels	I	I		Inspect as part of pre-ride inspection
Steering system			I Every 6 months	Inspect as part of pre-ride inspection
Suspension System			I	
C.V.T. Drive belt			I	Replace as needed
Transmission Oil			R or 100 hrs	
Engine Oil	I	I	R or 100 hrs	inspect as part of pre-ride inspection
Choke		I		
Spark Arrester			C every 100 hrs	R every 200 Hours
Battery			I, C	

I = Inspect, Clean, Adjust, Lubricate or Replace as needed

C= Clean

L = Lubricate

R = Replace

# Wiring Diagram

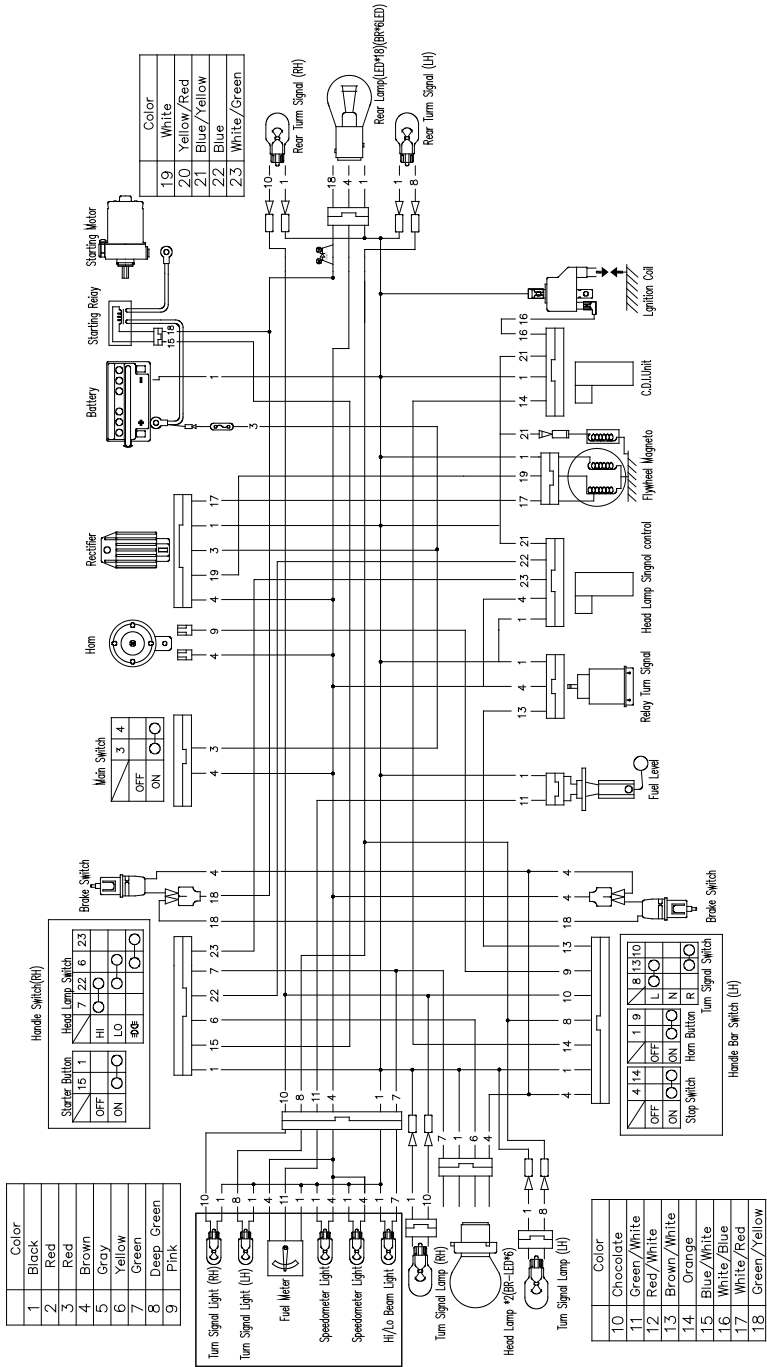

## **NHTSA Safety Notice**

**If you believe that your vehicle has a defect which could cause crash, injury, or death, you should immediately contact the National Highway Traffic Safety Administration (NHTSA) in addition to notifying ETON America, LLC.**

**If NHTSA receives similar complaints, it may open an investigation and if it finds that a safety defect exists in a group of vehicles, it may order a recall and remedy campaign. However, NHTSA cannot become involved in any individual problems between you, your dealer ETON America, LLC.**

**To contact NHTSA, you may call the vehicle safety hotline toll-free at 1-888-327-4236 (TTY: 1-800-424-9153);**

**or go to <http://www.safercar.gov>**

**or write to:  
Administrator  
NHTSA  
400 Seventh Street SW,  
Washington, DC 20590.**



# ETON AMERICA, LLC.

## LIMITED VEHICLE WARRANTY

ETON America warrants all new ETON vehicles sold by authorized ETON Dealers to be free from defects in materials and workmanship, subject to the following exclusions and limitations. New vehicles sold by an authorized dealer to original retail consumers are covered by this policy for a period of six (6) months from the date of delivery. There is no mileage limitation. This warranty is given to the original retail purchaser and is non-transferrable.

Vehicles used in rental service or for certain commercial purposes are specifically excluded from this policy. (Check with your dealer for warranty application.)

Items and conditions that are specifically excluded from this warranty program are;

1. Damage caused by accidents, misuse, negligence, improper vehicle operation,
2. Any modification or alteration to any standard specifications or equipment.
3. Any repairs made by an unauthorized dealer or service firm,
4. Use of non-ETON genuine parts for repairs or alteration to standard specifications.
5. Damage caused by failure to perform factory scheduled service-maintenance.
6. Damage which occurs as a result of improper storage.
7. Damage caused by the use of improper fuel or lubricants, and/or failure to use proper oil/gas mixture on two stroke models.

The following normal wear parts are specifically excluded from warranty coverage:

- |                                  |                               |
|----------------------------------|-------------------------------|
| 1. Rubber parts                  | 8. Filters                    |
| 2. Tires                         | 9. Spark plugs                |
| 3. Belts                         | 10. Bulbs                     |
| 4. Brake linings (after 30 days) | 11. Batteries (after 30 days) |
| 5. Normal wear item              | 12. Sprockets                 |
| 6. Brake parts                   | 13. External springs          |
| 7. Cables                        | 14. Seat and hand grips.      |

Scheduled maintenance service is the responsibility of the owner during and after the warranty period. In the event of a failure or required repair, the owner should take vehicle to an authorized dealer for repair without undue delay and within a maximum of thirty, (30), days of the occurrence of the problem. All eligible warranty repairs must be made at any authorized dealer's normal place of business. Any transportation costs, or other expenses which may occur in order to obtain warranty service, are the responsibility of the owner. All eligible repairs covered under this warranty will be paid to the servicing dealer only, by ETON America, and no additional payments shall be made for authorized warranty repairs.

Dealer and/or ETON America are not responsible for loss of use, other damage or inconvenience due to warranty repairs. It is the customer/buyer's responsibility to review with the selling dealer the pre-delivery service schedule to assure machine is properly serviced prior to delivery acceptance. It is recommended that the buyer take a test ride to familiarize themselves with the machine and to make certain the unit is in proper operating condition. The dealer is responsible for checking and performing all items on the "set-up and pre-delivery checklist" prior to delivery to the customer.



# ETON AMERICA, LLC.

## LIMITED VEHICLE WARRANTY

This warranty is valid at any authorized ETON Dealer in the United States only. In the event you experience any problem obtaining prompt service, contact ETON America, customer service department for assistance. Always consult first with your selling dealer and or service personnel for assistance with any service work or repairs. In the event you have a problem obtaining service send your name, address, and vehicle identification number to Eton America for assistance.

The above stated policy is the only policy offered and backed by ETON America, and no other organization or individual is authorized to make or offer any different arrangements. Some states prohibit certain limitations or conditions or do not allow exclusions or limitations. You may be eligible for additional consideration, so check with your local dealer or appropriate state agency for assistance. Rights vary from state to state, and you may have other rights not offered in this warranty.

ETON America warrants all new vehicles comply with applicable US regulations.

**LIMITATIONS.** This Limited Vehicle Warranty shall not cover any of the following: Repairs or replacement required as a result of (i) accident, (ii) misuse or neglect, (iii) lack of reasonable and proper maintenance, (iv) repairs improperly performed or replacement improperly installed, (v) use of replacement parts or accessories not conforming to ETON America LLC specifications which adversely affect

- 1) performance and/or durability, (vi) alterations or modifications not recommended or approved in writing by ETON America LLC, and/or (vii) use in competitive racing or related events.
- 2) Replacement of parts and other services and adjustments required for routine maintenance.
- 3) Any vehicle on which odometer mileage has been changed so that the actual mileage cannot be determined.

### LIMITED LIABILITY.

The liability of ETON America LLC under this Limited Vehicle Warranty is limited solely to the remedying of the defects in the materials or workmanship by any authorized ETON America LLC vehicle dealer at its place of business during customary business hours.

Please refer to ETON America LLC website: [www.etonamerica.com](http://www.etonamerica.com).

This warranty does not cover inconvenience or loss of use of the Scooter/moped vehicle, or transportation of the Scooter/moped vehicle to or from the ETON America LLC authorized dealer. ETON America LLC SHALL NOT BE LIABLE FOR ANY OTHER EXPENSE, LOSS OR DAMAGE, WHETHER DIRECT, INCIDENTAL, CONSEQUENTIAL OR EXEMPLARY ARISING IN CONNECTION WITH THE SALE OR USE OF OR INABILITY TO USE THE ETON America LLC SCOOTER/MOPED VEHICLE FOR ANY PURPOSE, SOME STATES DO NOT ALLOW THE EXCLUSION OR LIMITATION OF ANY INCIDENTAL OR CONSEQUENTIAL DAMAGES, SO THE ABOVE LIMITATION OR EXCLUSION MAY NOT APPLY TO YOU.



# ETON AMERICA, LLC.

## **SCOOTER/MOPED LIMITED WARRANTY FEDERAL EMISSION CONTROL SYSTEMS**

ETON America LLC warrants each new scooter/moped vehicle that includes as standard equipment a taillight and a stoplight;

c) Is designed, built and equipped so as to conform at the time of initial retail purchase with all applicable regulation of the United States Environmental Protection Agency ("US EPA") and:

d) Is free from defects in material and workmanship which would cause such Scooter/moped vehicle to fail to conform with applicable regulations of the US EPA, for a time period of two and a half (2.5) years and, depending on the engine displacement:

This warranty period shall begin on the date the Scooter/moped vehicle is delivered to the initial retail purchaser, or on the date the Scooter/moped vehicle is placed in service as demonstrator, rental, lease, or company Scooter/moped vehicle prior to retail sale.

5) **COVERAGE.** Warranty defects shall be remedied during customary business hours at any authorized ETON America LLC Scooter/moped dealer located within the United States in compliance with the Clean Air Act and applicable regulation of the US EPA. Any part or parts replaced under this warranty shall become the property of ETON America LLC.

6) **OWNERS OBLIGATION.** The following obligations must be fulfilled by the owner to maintain the validity of the ETON America LLC Emission Control System Warranty:

a) Owner must deliver the scooter/moped vehicle to an authorized ETON America LLC Scooter/moped vehicle dealer or equally qualified service facility for inspection, maintenance service and adjustments according to the Periodic maintenance chart provided as part of, or supplemental to the Owner's manual. Optionally, the Owner may perform this maintenance only if it is within the scope of the Owner's technical and practical ability, keeping in mind some maintenance operations may require special tools or technical expertise beyond the scope of the average Owner. In any event, the inspection, maintenance and adjustments are to be performed at the Owner's expense.

b) Owner must present a copy of the proof of initial retail purchase date, issued at the time of purchase to an authorized ETON America LLC Scooter/moped vehicle dealer at the time warranty repairs are performed on the Scooter/moped vehicle. You may also be required to show that you have performed the required maintenance which is related to the alleged defect, so you should have detail receipts indicating that the required periodic maintenance has been performed in accordance with the periodic maintenance chart in your Owner's manual.



# ETON AMERICA, LLC.

## **SCOOTER/MOPED LIMITED WARRANTY FEDERAL EMISSION CONTROL SYSTEMS**

7) LIMITATIONS. This Emission Control System Warranty shall not cover any of the following:

- a) Repairs or replacement required as a result of (i) accident, (ii) misuse or neglect, (iii) lack of reasonable and proper maintenance, (iv) repairs improperly performed or replacement improperly installed, (v) use of replacement parts or accessories not conforming to ETON America LLC specifications which adversely affect performance and/or durability, (vi) alterations or modifications not recommended or approved in writing by ETON America LLC, and/or (vii) use in competitive racing or related events.
- b) Replacement of parts and other services and adjustments required for routine maintenance.
- c) Any Scooter/moped vehicle on which odometer mileage has been changed so that the actual mileage cannot be determined.

8) LIMITED LIABILITY.

a) The liability of ETON America LLC under this Emission Control System Warranty is limited solely to the remedying of the defects in the materials or workmanship by any authorized ETON America LLC Scooter/moped vehicle dealer at its place of business during customary business hours. Please refer to ETON America LLC website: [www.etonamerica.com](http://www.etonamerica.com). This warranty does not cover inconvenience or loss of use of the Scooter/moped vehicle, or transportation of the Scooter/moped vehicle to or from the ETON America LLC authorized dealer. ETON America LLC SHALL NOT BE LIABLE FOR ANY OTHER EXPENSE, LOSS OR DAMAGE, WHETHER DIRECT, INCIDENTAL, CONSEQUENTIAL OR EXEMPLARY ARISING IN CONNECTION WITH THE SALE OR USE OF OR INABILITY TO USE THE ETON America LLC SCOOTER/MOPED VEHICLE FOR ANY PURPOSE, SOME STATES DO NOT ALLOW THE EXCLUSION OR LIMITATION OF ANY INCIDENTAL OR CONSEQUENTIAL DAMAGES, SO THE ABOVE LIMITATION OR EXCLUSION MAY NOT APPLY TO YOU.

